

Jan. 28, 1941.

F. S. ROBBINS  
LOCOMOTIVE PILOT  
Filed July 19, 1940

Des. 124,906

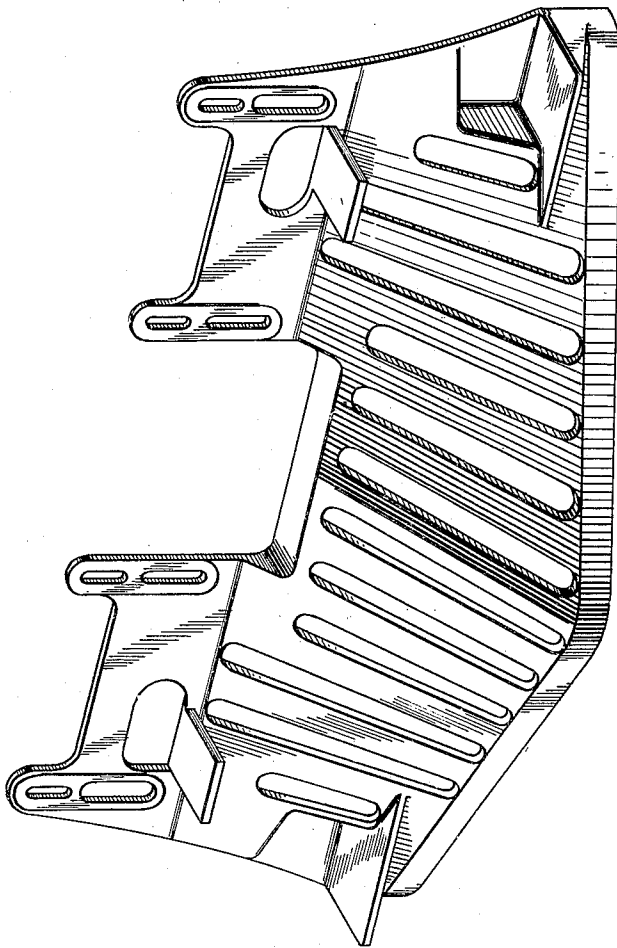

Inventor

*Frank S. Robbins.*

By *Cushman, Hart & Cushman*  
Attorneys

# UNITED STATES PATENT OFFICE

124,906

## DESIGN FOR A LOCOMOTIVE PILOT

Frank S. Robbins, Wilmington, N. C., assignor to  
Ross-Meehan Foundries, Chattanooga, Tenn.,  
a corporation of Tennessee

Application July 19, 1940, Serial No. 93,793

Term of patent 14 years

*To all whom it may concern:*

Be it known that I, Frank S. Robbins, a citizen of the United States, residing at Wilmington, county of New Hanover, State of North Carolina, have invented a new, original, and ornamental Design for a Locomotive Pilot, of which the following is a specification, reference being had to the accompanying drawing, forming a part thereof.

The figure is a perspective view of a locomotive pilot showing my new design.

The dominating features of the design consist in the staggered arrangement of each set of

upper and lower steps, and the built-in arrangement of the steps wherein the front edge of each lower step is straight and substantially parallel to the back line of the pilot and gradually merges into the inclined front face of the pilot, the rear portion of each lower step extending into a recessed portion of the pilot, all of said elements being located within the confines of the sides of the pilot.

I claim:

The ornamental design for a locomotive pilot, substantially as shown and described.

FRANK S. ROBBINS.