

J. S. CHAMBERS.
THROTTLE VALVE.

APPLICATION FILED APR. 14, 1904.

3 SHEETS—SHEET 1.

Fig. 1.

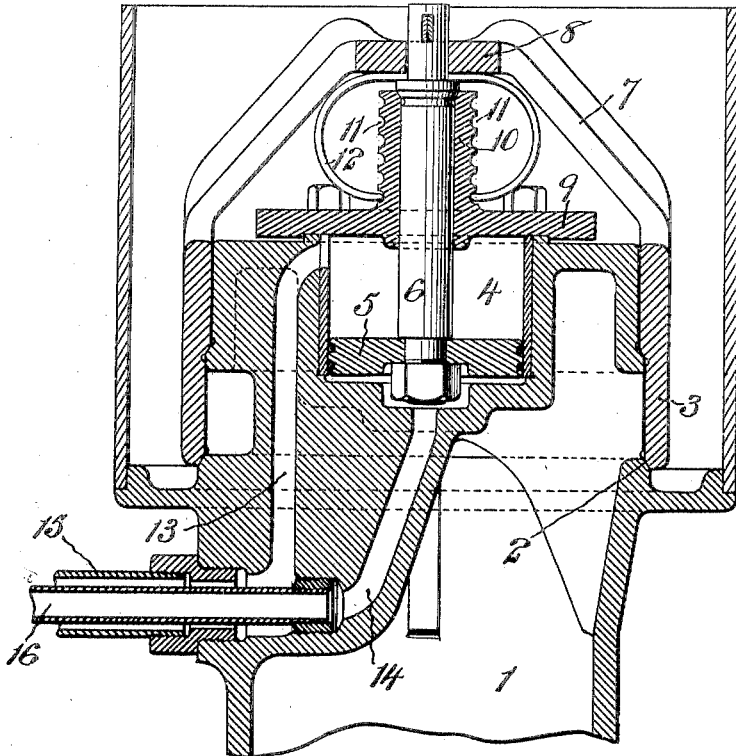

Fig. 2.

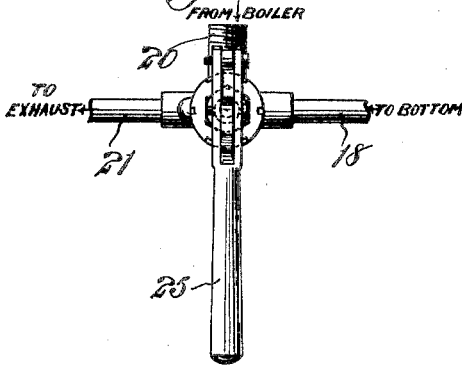

Fig. 3.

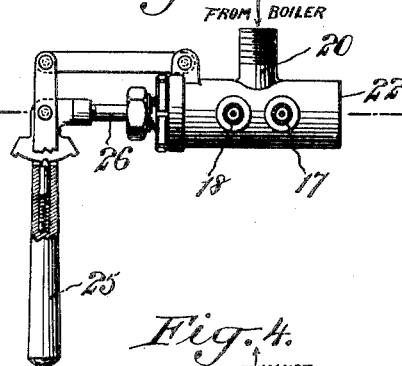
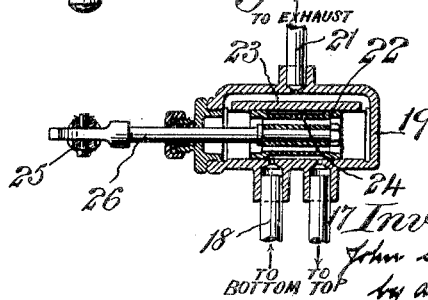

Fig. 4.



Witnesses:
F. George Barry,
Harry Thiel

Inventor:
John S. Chambers
by attorneys
Brown & Burdick

J. S. CHAMBERS.
THROTTLE VALVE.

APPLICATION FILED APR. 14, 1904.

3 SHEETS—SHEET 2.

Fig. 5.

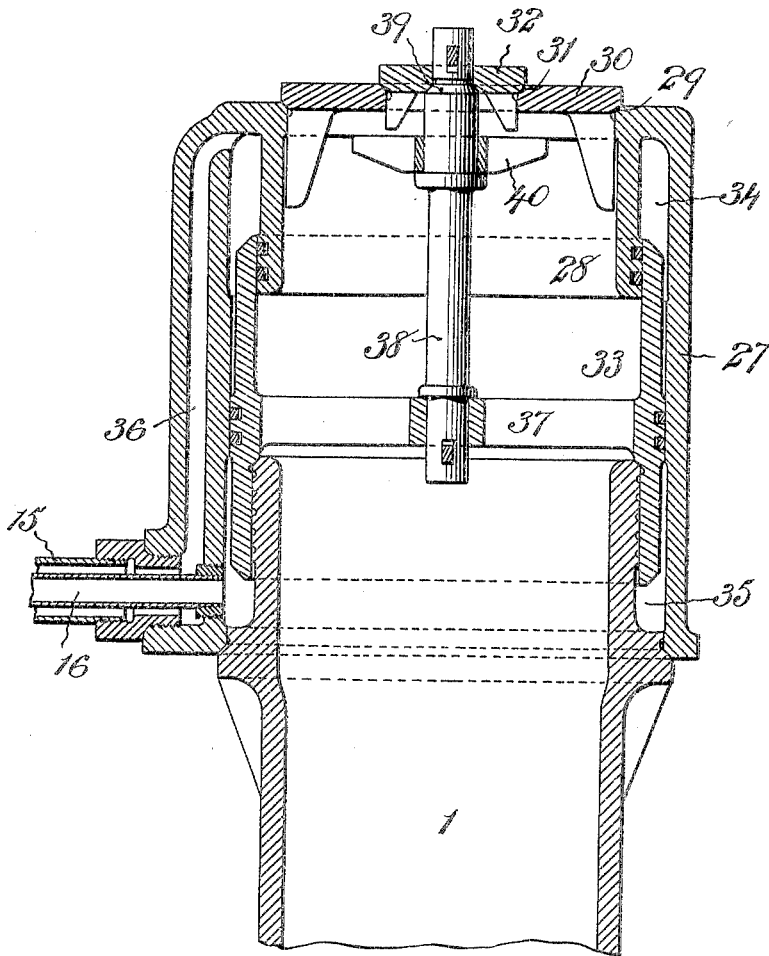

*Witnesses:-
F. George Barry
Henry Thieling*

*Inventor:
John S. Chambers
by attorneys
Brown & Howard*

J. S. CHAMBERS.
THROTTLE VALVE.
APPLICATION FILED APR. 14, 1904.

Fig. 6.

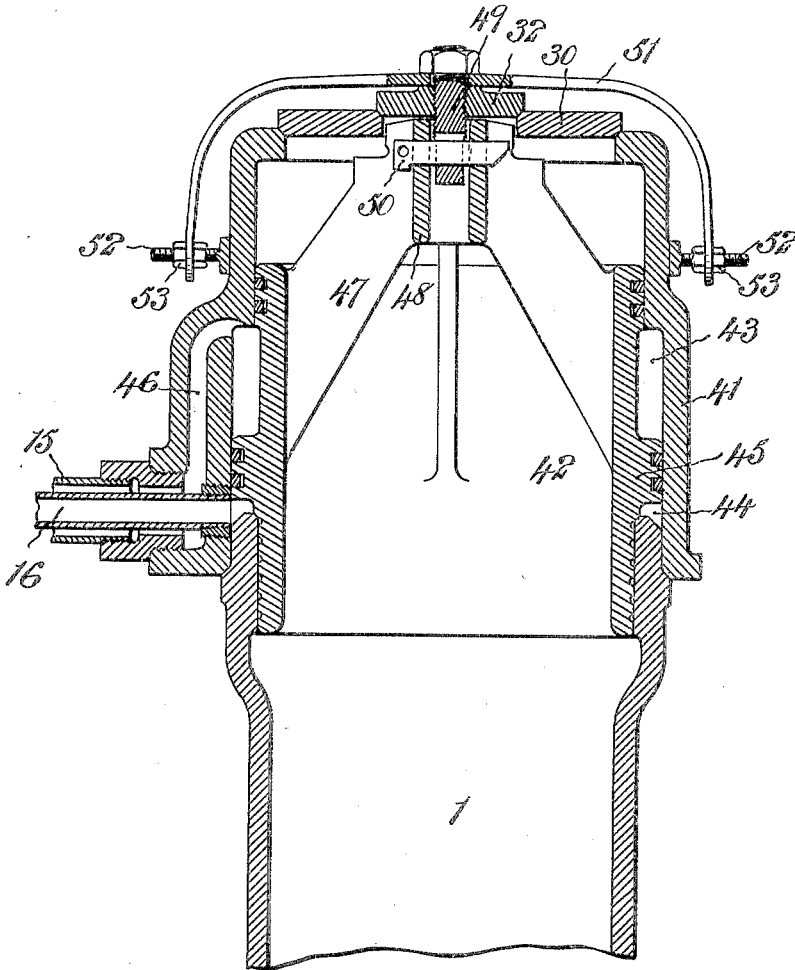

Witnesses:-
F. George Barry,
Henry Thieme.

Inventor:
John S. Chambers
by attorneys
Thomson & Seward

UNITED STATES PATENT OFFICE.

JOHN S. CHAMBERS, OF WILMINGTON, NORTH CAROLINA.

THROTTLE-VALVE.

SPECIFICATION forming part of Letters Patent No. 793,822, dated July 4, 1905.

Application filed April 14, 1904. Serial No. 203,218.

To all whom it may concern:

Be it known that I, JOHN S. CHAMBERS, a citizen of the United States, and a resident of Wilmington, in the county of New Hanover and State of North Carolina, have invented a new and useful Improvement in Throttle-Valves, of which the following is a specification.

My invention relates to an improvement in throttle-valves, and has for its object to provide pressure-actuated means for operating the valve.

My invention more particularly consists in providing a piston for controlling the movements of the valve and an operating-valve arranged to control the admission of power to one or the other side of the piston or to both sides of the piston at pleasure, whereby the piston, and thereby the valve, may be raised and then held in such raised position.

Practical embodiments of my invention are represented in the accompanying drawings, in which—

Figure 1 represents in vertical central section one form of a single valve, a piston connected thereto, its chamber, and the arrangement of ports for admitting power to both sides of the piston. Fig. 2 is an end view of a suitable operating-valve for controlling the admission of the power to one side or the other of the piston or to both sides simultaneously. Fig. 3 is a side view of the operating-valve. Fig. 4 is a longitudinal central section through the same. Fig. 5 is a vertical central section through one form of duplicate valve with my invention applied thereto, and Fig. 6 is a vertical central section of another form of duplicate valve with my invention applied thereto.

In the form shown in Fig. 1 the vertical stand-pipe is denoted by 1, its valve-seat by 2, and the annular valve therefor by 3. These may be of any well known or approved form. The top of the stand-pipe 1 is extended upwardly within the annular valve 3 and is there provided with a cylinder 4, within which is fitted to slide vertically a piston 5, the rod 6 of which is connected to the valve 3 by providing the valve with inwardly-extended arms 7, leading to a hub 8, spaced a short distance above the top of the cylinder-head 9, which

is secured to the stand-pipe 1. This cylinder-head 9 is provided with a centrally-arranged upwardly-projected hub 10, which hub is provided with two vertical series of notches 11. The weight of the valve 3, the piston 5, and its rod 6 is partially supported by the stand-pipe 1 through a spring 12, interposed between the hub 8 and the cylinder-head 9. In the present instance this spring is shown as being provided with two branches arranged to engage a predetermined pair of notches 11 in the hub 10 for adjusting the tension of the spring. Ports 13 and 14 open into the piston-chamber 4 upon opposite sides of the piston 5, which ports are connected to tubes 15 and 16, respectively, which connect with tubes 17 and 18 of an operating-valve casing 19, located at any convenient point. This operating-valve casing 19 is provided with the usual inlet 20 from the boiler, the admission of steam from the boiler being controlled in any well-known manner. This operating-valve casing 19 is also provided with an exhaust 21. The valve-casing 19 is provided with a branch port 23, leading from the opposite sides of the valve 22 to the exhaust. This valve 22 is also provided with a bridge-port 24, arranged to open communication between the tubes 17 and 18, which connect, through the tubes 15 and 16, with the ports 13 and 14, leading to the top and bottom of the valve-operating piston-chamber 4 when the valve 22 is in its intermediate position. This port 24 is at all times in communication with the inlet 20 from the boiler. When the valve 22 is at the limit of its movement in one direction, communication will be established from the tube 17 to the exhaust, and when the valve is at the limit of its movement in the other direction communication will be established from the tube 18 to the exhaust. A suitable handle 25 is arranged to slide the valve 22 by means of the rod 26 into any one of the three positions above referred to.

Fig. 5 represents a form in which the stand-pipe is provided with a cylindrical extension 27, the lower end of which overlaps and is spaced from the upper end of the stand-pipe and the upper end of which is provided with a cylindrical downward extension 28, spaced

from the outer wall. In this form a seat 29 is provided for the valve 30, and the valve 30 is provided with a seat 31 for a smaller valve 32. The valve-controlling annular piston is denoted by 33, and its outer wall engages the inner wall of the extension 27, while its inner wall engages the outer walls of the downward extension 28 and the upward extension of the stand-pipe, thus forming piston-chambers 34 35 upon both sides of the piston. The port 36, leading to the upper chamber 34, communicates with the tube 15, and the tube 16 communicates directly with the lower piston-chamber 35. This piston 33 is connected by a spider 37 with its rod 38, which rod is provided with a shoulder 39, fitted to raise the inner valve 32, and a shoulder 40, fitted to raise the outer valve 30.

In the form shown in Fig. 6 the upward extension of the stand-pipe 1 is denoted by 41, and the use of the downward extension 28, as in the form shown in Fig. 5, is obviated. The annular piston 42 for controlling the movements of the valves 30 and 32 is provided on its periphery with an upper portion fitted to engage the inner wall of the upper reduced portion of the extension 41, an intermediate portion fitted to engage the lower enlarged portion of the extension 41, and its lower end fitted to engage the inner wall of the stand-pipe 1. Upper and lower piston-chambers 43 44 are thus formed on the opposite sides of the intermediate portion 45 of the piston. A port 46 leads from the tube 15 to the piston-chamber 43 upon one side of the valve 42, and the tube 16 communicates directly with the piston-chamber 44 upon the other side of the said valve. In this form the piston 42 is provided with inwardly-extended arms 47, leading to a hub 48, to which a central bolt 49, carried by the inner valve 32, is loosely connected by a key 50. In this form the weight of the piston is partially counterbalanced by a spring 49 on the top of the inner valve 32, the arms of which spring are adjustably secured to laterally-projected bolts 52 on the exterior of the reduced portion of the extension 41 by nuts 53 for adjusting the tension of the spring.

In operation power is first admitted to the operating-valve from the boiler, the operating-valve being in its intermediate position. The valve-casing is then shifted by the handle 25 to the limit of its movement in position to open communication from the tube 17 to the exhaust 21, thus reducing the pressure upon the top of the valve. The pressure from the boiler will still continue through the tube 18 to the bottom of the piston, thus raising the piston, and thereby raising the valve. When

the valve has been raised, the handle 25 may be operated to bring the operating-valve casing into its intermediate position, thus supplying an equal amount of pressure to both sides of the piston, and thereby holding the valve raised. When it is desired to close the throttle-valve, the handle 25 of the operating-valve is moved in a direction to open the bottom of the throttle-valve piston to the exhaust.

It is evident that this invention might be applied to many different forms of valves. Hence I do not wish to limit myself strictly to the forms herein set forth; but

What I claim is—

1. In a throttle-valve, the combination with a valve-seat and a main valve for opening and closing communication between the interior of the stand-pipe and the surrounding medium, the stand-pipe being further provided with an extension containing a cylinder, of a piston-valve located in the cylinder and connected with the main valve, and means under the control of the operator for admitting power to the piston-valve to operate it and hence the main valve.

2. In a throttle-valve, the combination with the stand-pipe provided with a valve-seat and a main valve for opening and closing communication between the interior of the stand-pipe and the surrounding medium, the said stand-pipe being further provided with an extension containing a cylinder, of a piston-valve located in the cylinder and connected with the main valve, and a valve under the control of the operator for admitting power to the piston-valve to move it in either of two opposite directions and for maintaining the said valve in any desired position.

3. In a throttle-valve, the combination with the stand-pipe provided with a valve-seat and a main valve for opening and closing communication between the interior of the stand-pipe and the surrounding medium, the said stand-pipe being further provided with an extension containing a cylinder, of a piston-valve located in the cylinder and connected with the main valve, a spring for counterbalancing the weight of the main valve and means under the control of the operator for admitting power to the piston-valve to operate it and hence the main valve.

In testimony that I claim the foregoing as my invention I have signed my name, in presence of two witnesses, this 9th day of April, 1904.

JOHN S. CHAMBERS.

Witnesses:

O. M. BUTLER,
J. C. ANGEL.