

H. Lam,

Wood Planing Machine.

N^o 2,272.

Patented Sep. 30, 1841.

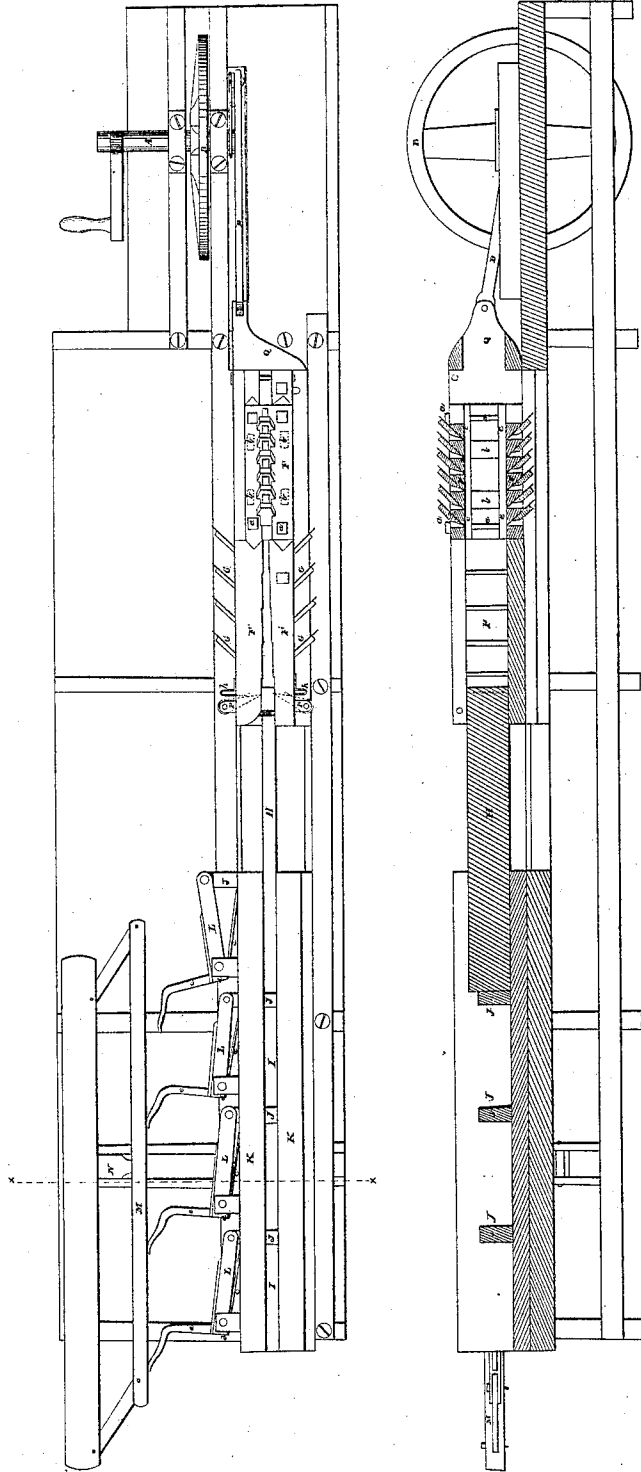

H. Lan,

Wood Planing Machine.

N^o 2,272.

Patented Sep. 30, 1841.

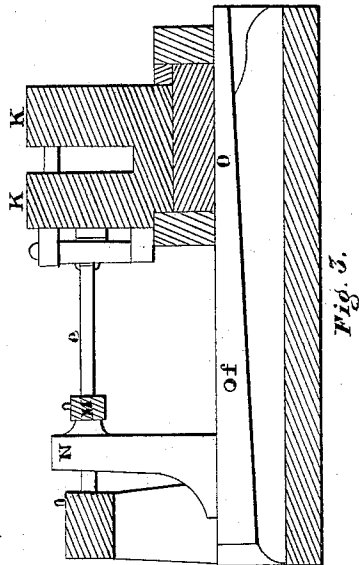
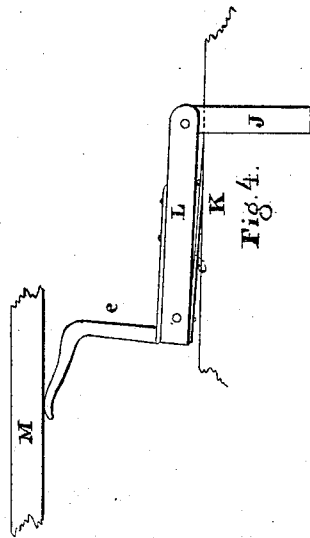

UNITED STATES PATENT OFFICE.

H. LAW, OF WILMINGTON, NORTH CAROLINA.

MACHINE FOR PLANING BOARDS AND TIMBER OF OTHER KINDS.

Specification of Letters Patent No. 2,272, dated September 30, 1841.

To all whom it may concern:

Be it known that I, HERVEY LAW, of the city of Wilmington, in the county of New Hanover and State of North Carolina, have invented a new and useful machine for the planing of timber of various kinds, by means of which machine boards may be planed on both sides and tongued and grooved at the same time or stuff of various kinds may be planed on one, two, three, or four sides, as may be preferred; and I do hereby declare that the following is a full and exact description thereof.

In describing my machine, I will suppose it to be applied to the planing of boards on both sides, and to the tonguing and grooving of their edges, as its application to planing in general will be thereby rendered manifest. The board to be planed is to be dropped into a trough, or space, prepared to receive it, edgewise, one end of said board projecting out beyond the end of said trough, toward the plane stocks. The end at which the stuff is fed in I will call the fore end of the machine. The plane stocks are made to slide back and forth, horizontally, between suitable guides, a reciprocating motion being given to them by means of a shackle bar, or connecting rod, vibrated by a crank, and attached at one end to the plane stock apparatus. The shaft of the crank is placed horizontally, and has a fly wheel upon it, to regulate its motion; and this shaft may be driven by any adequate power. The crank may, in a machine of ordinary size, have a throw of seven inches, giving a vibration of fourteen inches to the plane stocks. As these stocks vibrate they approach the projecting end of the board contained in the trough, and said board passes in between them, and is seized and held by two iron grippers, which draw it onward toward the rear end of the machine, as the plane stocks recede from, but let go their hold as they advance toward, the trough. When the board has been drawn to a suitable distance out of the trough, by the receding of the plane stocks, there is forced in at its fore end, a bar of wood, or of metal, which serves as an abutment to prevent its return when it is being acted upon by the plane irons. There is a series of such bars, or abutments, crossing the trough from side to side, at the distance of about a foot from each other when the vibration of the plane stocks is equal to about

thirteen, or fourteen inches; the falling in of a fresh abutment at every stroke of the planes will be thus insured; and in this way twelve inches of the board will be planed at each vibration of the plane stocks.

In the accompanying drawings, Figure 1, is a top view of my planing machine, and Fig. 2, a longitudinal, vertical section of it in a line which would cut the tonguing and grooving planes through their centers.

In each of these figures like parts are designated by the same letters of reference.

A, is the driving, or crank, shaft; B, the fly wheel; C, the crank, and E, the connecting rod, or shackle bar, which gives motion to the plane stocks F, F.

The board, shown at H, is received between the side stocks F', F', which hold the plane irons G, G; these irons being fastened by wedges in the ordinary way, or by any other suitable means; the most advanced of these irons operate as jack plane irons, while the last of the series operates as a smoothing plane iron. The stocks F', F', are a little closer together at their rear, than at their fore ends, there being an offset on their faces at each successive iron, equal to the cut of such iron. The board is to be completely planed on its two sides in passing between the stocks F', F', the irons being of such width as may be required to effect this object. After passing the planing stocks F', F', it passes between the upper and lower tonguing and grooving stocks F'', F'', immediately in the rear of the former, and constituting a part of the same vibrating apparatus. The irons in these upper and lower stocks are set like those for planing the sides, so that each will cut deeper than that preceding it, the last extending to the required depth for the tongue, or groove. The stocks F', F', may be adjusted in their distance apart, by means of the screw bolts which confine them in place, so as to adapt them to stuff of different thickness; and the tonguing and grooving part is also adjustable to different widths. The lower stock I make immovable, but the upper one may be raised or lowered. This may be done by means of the screw bolts a, a, and the blocks b, b, interposed between the upper and lower stocks, near their edges c, c; so as to be out of the way of the action of the grooving irons; blocks of varying lengths are to be provided for the purpose; the same effect may be produced by an arrangement of set

screws, in a way well understood by machinists, or by various equivalent means in common use.

I, I, is the trough for receiving the boards to be planed, and J, J, are the bars which form the abutments that sustain the pressure against their ends from the action of the plane irons. Only four of these abutments are shown in the drawing, but there must be as many as the number of feet in the length of the board to be planed, provided they are placed at the distance of one foot apart. These abutment bars slide through mortises in the cheeks K, K, of the trough I, I, into which they are carried by springs c' , c' , attached to the cheek of the trough, and bearing against the rear ends d , d , of the jointed levers L, L. When a board is to be dropped into the trough, the abutment bars must be withdrawn; but there may be a permanent abutment adapted to the length of the board.

For the purpose of withdrawing the abutments, the following device may be resorted to. The levers L, L, may have iron, or other, tail pieces e , e , attached to them, the outer ends of which bear against a jointed bar M, which bar may be forced against the tail-pieces by a standard N, moved forward by means of a treadle. Fig. 3, is a vertical, cross section of the machine in the line X X, Fig. 1, O, being the treadle working on a fulcrum pin f , to advance the jointed bar M; there may be more than one treadle and jointed bar to operate the abutments. Fig. 4, is a horizontal section through one of the abutment bars, and its immediate appendages. The abutment bars may be carried in and out of the trough in various ways, which will suggest themselves to every competent machinist, but in the foregoing description I have given that which I have essayed, and which has operated satisfactorily; but my machine is not dependent upon a minor arrangement of this kind, nor is it my design to limit myself in this particular to the precise combination of the abutments, levers and jointed bar as above set forth.

P, P, Fig. 1, are the two iron grippers, shown in part by dotted lines, which seize and hold the board, and draw it from the trough I. These grippers pass through mortises in the fore ends of the plane stocks F'' , F'' , work upon suitable joint pins on the outside thereof, as represented, point back in the manner shown by the dotted lines, and are borne up by springs h , h ; it will be manifest that as the plane stocks advance upon the board, these gripping pieces will loose their hold, and slide upon it, but that when the plane stocks recede they will carry the board with them and allow a new abutment bar to fall in at its extreme, or fore, end. The board is thus passed on in sections toward the cutters, or plane irons,

at every vibration; and these, as they advance toward the trough, plane it to the distance of a foot, more or less, according to the construction of the machine. When a board has been thus carried into the stocks to the full extent to which the last abutment bar can advance it, a fresh board is dropped into the trough, and extending beyond its rear end to a distance sufficient to enable the gripping pieces to seize it; this last board then becomes the driver of that which preceded it, causing it to advance until it is forced entirely through the plane stocks in a finished state; passing thence through an opening made for the purpose at Q, in the rear end of the plane stock apparatus.

When scantling, or other timber, is to be planed on four sides, the tonguing and grooving stocks are to be removed, and their places occupied by plane stocks similar to those shown at F' , F' ; the latter stocks being, of course, placed at such distance from each other as to adapt them to the stuff to be planed; plane stocks of different widths, also, should be provided, so as to be applied to the apparatus, and to suit stuff of different sizes. It will be readily seen that by substituting a stock, or stocks, not provided with plane irons, for one, or more, of the stocks furnished therewith, timber may be planed simultaneously on one, two, or three sides only, as may be required. When tongued and grooved boards are planed on both sides, if care be taken to adjust the apparatus so that the tongue and groove shall be exactly in the middle of the board, its fairest side may always be turned outward, or uppermost, on a floor, or otherwise.

My invention is to give such a velocity to my fly wheel as shall cause it to make about one hundred and twenty-five revolutions in a minute; and with a machine by which a foot in length is planed at each vibration, one hundred and twenty-five feet in length would be planed in a minute. The rapidity of the motion of the machine must, however, be regulated by the size and kind of timber to be planed; and this must be done in accordance with the judgment and experience of the person having charge of the machine.

I intend, sometimes, to modify this machine in such manner as to allow the plane stocks to be stationary during the operation of planing, and to give a reciprocating motion to the apparatus by which the board is fed in between them, and am of opinion that this mode of construction will be, for some purposes, preferable to the vibrating of the plane stocks; this plan I consider as substantially the same with that herein described, but still, it is my intention when I have ascertained, by experiment, the best arrangement of the parts for carrying said modification into effect, to add the same, as

an improvement, to the Letters Patent which I now solicit for the within described machine.

Having thus fully described the nature of my machine for planing boards, and other kinds of timber, and explained the operation thereof, what I claim therein as new, and as of my invention, and which I desire to secure by Letters Patent, is:

1. The manner herein set forth of planing boards, plank, or other timber, by means of reciprocating, or vibrating, plane stocks, operating upon stuff held by the iron grippers P, P, and which stocks are to be moved back and forth to a short distance, say to that of a foot, more or less, and are to operate upon a corresponding length of the board, or other timber to be planed, by means of a plane stock apparatus like that herein described.

2. And I also claim, in combination with such reciprocating plane stocks, the manner of feeding the stuff to the planes, and of sustaining it against their action, by the combined operation of the grippers which

are to seize and to draw the stuff back with the backward motion of the plane stock, and of the sliding bars, or abutments, which are made successively to pass in at the fore end of the stuff, and sustain it against the action of the cutting, or plane, irons.

And I do hereby declare that I do not intend by the description, herein given, of the manner of forming and arranging the auxiliary parts of the apparatus, to limit or confine myself to the precise form of these parts, but to vary them as I may find expedient, while the general construction and operation of the machine remain substantially the same with that herein set forth; and while it is made to retain those features by which it is distinguished from all other machines which have hitherto been constructed for the same purpose.

HERVEY LAW.

Witnesses:

THOS. P. JONES,
ISAIAH JENNINGS.